

Developing an Improved Impinger-Based Method for Measuring Gaseous Hydrogen Chloride in Cement and Lime Kiln Emissions

Laura L. Kinner and James W. Peeler
Emission Monitoring Inc.
Raleigh, NC 27612

Daniel A. Willis
Blue Circle Cement
Marietta, GA 30067

ABSTRACT

The measurement of gaseous hydrogen chloride (HCl) in Portland cement and lime kiln effluent poses great challenges because of the reactive nature of both the HCl and the entrained dust in the effluent. It will become necessary for these calcining facilities to measure HCl for the purpose of National Emission Standards for Hazardous Air Pollutant (NESHAP) or area source determinations, demonstrating compliance with state/local regulations, and/or establishing emissions inventories for air permits.

Currently, Fourier transform infrared-based EPA Methods 320/321 are the only methods in the EPA promulgated Portland cement NESHAP Rule allowed to determine the 10 ton/year threshold for HCl MACT standard applicability at Portland cement plants¹. Because this method can be an economic disadvantage for many companies, the Portland Cement Association and the National Lime Association sponsored a laboratory investigation to compare directly FTIR and an improved impinger-based method similar to EPA Method 26².

The purpose of the laboratory study was to: 1) improve understanding of the complex HCl measurement issues, 2) solve the immediate problem associated with measurement of HCl by EPA Method 26 relative to infrared-based analyzers, and 3) to derive an improved impinger –based measurement method that is acceptable to industry, that is more cost effective than IR-based methods, and that provides facilities a choice of HCl measurement methods.

An American Society for Testing and Materials (ASTM) is presently drafting a method to measure gaseous chlorides from mineral calcining industries based on this effort. It is expected that the ASTM Method will be completed within the next year pending the results of field testing applications. This paper presents the results of the comparative laboratory study, and the improvements to Method 26 that will be incorporated into the ASTM test method.

INTRODUCTION

In the past, numerous studies regarding HCl measurement in various effluent matrices have been conducted by EPA and by industry. Much of this work has fueled speculations regarding how and why these measurement methods failed in the various applications, and has evolved sometimes-mythological explanations about the reported results. Many issues remain misunderstood about the measurement of reactive condensable gases such as HCl, and much of the applicable knowledge from successful emissions tests has not been disseminated through the regulatory and measurement community.

Work sponsored by the Portland Cement Association in 1996 resulted in developing Fourier transform infrared (FTIR) and gas filter correlation (GFCIR) based measurement methods that were validated by the cement industry using EPA Method 301. Some of this work involved the concurrent measurement of HCl using EPA Method 26. Because of sampling system discrepancies between the methods, results for Method 26 were low relative to GFCIR measurements. The EPA subsequently indicated in its proposal of the Portland cement MACT Standard³ that validation of Method 26 was required on a kiln by kiln basis using an infrared-based analyzer as the reference method. Successful validation would then allow use of the impinger method at that facility only.

In the summer of 1998, GFCIR work was performed by EPA contractors in gathering data for a future proposed MACT standard in the Lime industry. The poor results from these tests formed the basis for the EPA disallowing use of the GFCIR test method in their promulgation of the Portland cement MACT Standard⁴. This EPA rulemaking decision reduced the HCl test method options to that of FTIR only.

Because of these circumstances, the Portland Cement Association (PCA) and the National Lime Association (NLA) funded a program to demonstrate that simple modifications to Method 26 can produce data of known accuracy and precision, and can provide results comparable to instrumental infrared analyzers. Demonstration of method equivalency would allow member companies to choose which measurement technique best fits the technical and economical requirements of the particular test situation.

Emission Monitoring was retained to develop an improved impinger method starting first with a laboratory investigation. The approach was intended to solve the immediate measurement problem with respect to Method 26 and the IR-based methods in the most cost-effective manner. It was not a comprehensive study, nor was it designed to determine the specific chemical reactions/mechanisms that cause the discrepancies between the impinger and the IR-based methods.

The laboratory study was divided into iterative experiments to determine the adsorptive nature of glassware and two types of filter media as a function of sampling system temperature. The first series of experiments were conducted using HCl calibration gases in dry nitrogen. These experiments were performed both with and without cement kiln dust (CKD) loaded onto the two types of filters.

After deducing the optimal sampling system temperature, and filtration media, experiments were then performed using simulated effluent (i.e., SO₂, ammonia, and moisture). Simulated effluent and HCl calibration gas was used in the presence of dust samples to determine how these parameters effected quantifying HCl. Finally, as a test of the improved impinger method, comparative studies were conducted between an FTIR and the modified version of Method 26.

LABORATORY STUDIES

The laboratory study was conducted from July 21 through 28, 1999 at Clean Air Engineering's headquarters located in Palatine, Illinois. Clean Air provided the laboratory facilities and the FTIR instrumentation, and also conducted the ion chromatographic analyses of the impinger solutions. This was a well-suited facility from which to conduct these studies because of the proximity to the PCA Campus. Representatives from PCA and member companies were on-site to observe some of the laboratory work.

The laboratory study was divided into simple and complex experiments. These experiments investigated the adsorptive nature of glassware and two common types of filter media as a function of sampling system temperature and degree of sampling system conditioning (i.e., exposure to HCl in simulated cement and lime kiln stack gas).

Adsorption experiments were conducted using dry HCl calibration gases only, and then HCl calibration gas in the presence of simulated kiln gas and either cement or lime kiln dust (CKD or LKD).

Comparative experiments were then performed between the FTIR and the improved impinger method to determine; 1) the degree to which these methods agreed with each other, and 2) the degree to which they could quantify accurately HCl at concentration levels of concern to industry (typically from 5-25 PPM).

The following table presents a summary of the laboratory experiments.

Table 1 – Experiment Description and Simulated Effluent Matrix for Laboratory Studies

Experimental Condition	% H ₂ O Vapor	HCl – PPM	SO ₂ – PPM	% - O ₂	NH ₃ - PPM
PART I <u>Temperature and Filtration media studies</u> Quartz Vs Teflon Filters	7%	10	245	15%	None
PART II <u>HCl Evolution Studies</u> 1.0 g of CKD and LKD on UHP quartz filters at 350°F	10%	None	109	5%	None

Table 1 (cont.)

PART II					
<u>HCl Adsorption Studies</u>					
0.05 g CKD #1	7%	10	245/475/0	15%	None
0.05 g CKD #2	7%	10	0/245/475	18%	None
0.05 g LKD (50:50 blend)	7%	13	0/245/475	18%	O/10/40
PART III					
<u>Improved Impinger Method</u>					
<u>/FTIR Comparisons</u>					
	6%	9	212	15.5%	None
0.05 g CKD #1	6%	9	212	15.5%	None
0.05 g CKD #2	6%	9	212	15.5%	None
0.05 g CKD #3	6%	9	212	15.5%	None
0.05 g LKD (50:50 blend)					
	12%	9	200	14.5%	None
0.05 g CKD #1	12%	9	200	14.5%	None
0.05 g CKD #2	12%	25	200	13.5%	None
0.05 g CKD #3	12%	5	200	15%	None
0.05 g LKD (50:50 blend)					

PART I – Effect of Measurement System Temperature and Filtration Media

The purpose of these experiments was to investigate the effects on HCl quantification due to; 1) conditioning the front half of the impinger glassware (i.e., probe, filter holder and filter), 2) temperature, and 3) filtration media. An FTIR was used to measure the upscale and downscale response time for dry HCl calibration gas under these varying experimental parameters. Figure 1. presents a schematic of the experimental apparatus.

Dilutions of a manufacturer’s certified 165-PPM standard ($\pm 5\%$ accuracy) were performed to generate the different HCl concentrations used during this study. The dilution system consisted of a series of mass flow meters calibrated specifically for this test program using a digital flow meter with a NIST traceable standard. (see Figure 1)

Fresh, unconditioned Method 26 front half probes and filter holders were assembled and the time required to achieve a stable 99% upscale response for a 10 ppm standard of dry HCl calibration gas was measured at temperatures of 250°F and 350°F. This experiment was repeated to determine the effect on response time for conditioned glassware.

Teflon and ultra high purity quartz filters manufactured by Pallflex (0.3 μ) were evaluated side by side to determine the degree of HCl adsorption versus time at 350°F.

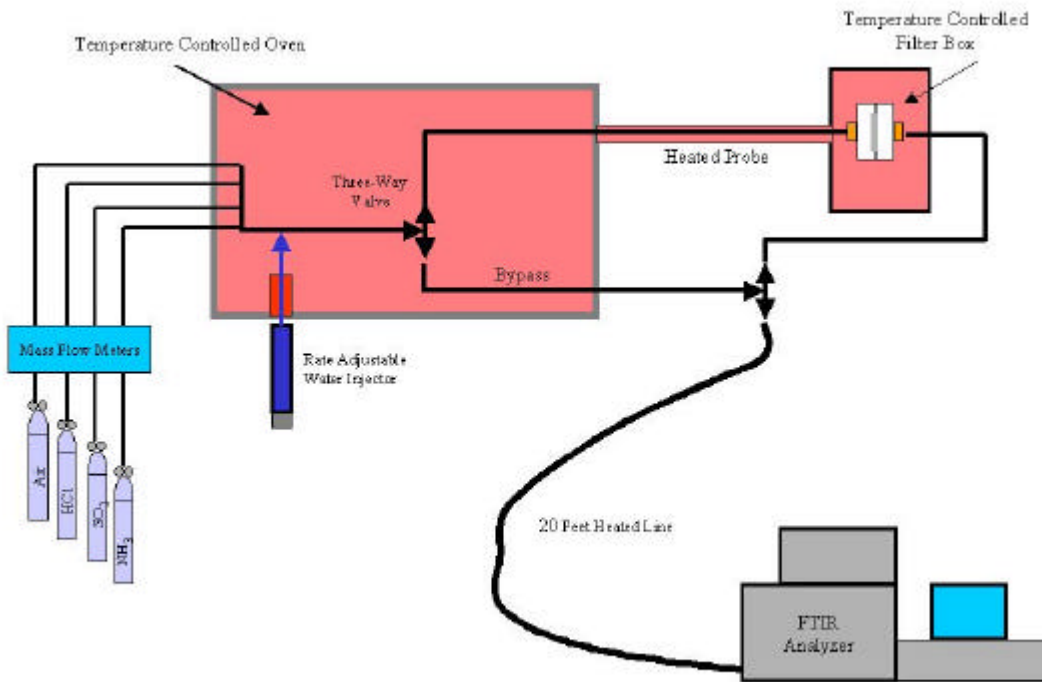

Figure 1. Method 26 Front Half Equilibration Study Apparatus

Part I - Results

The time required to achieve a stable 99% upscale and downscale (zero) measurement system response was greater than 50 minutes for 10 ppm of HCl at 250°F and a 2 liters per minute flowrate using the "fresh" (off the shelf) front half glassware. Stable response times for conditioned glassware at the same temperature and flowrate was greater than 40 minutes.

The time to achieve a stable upscale and downscale response at 350°F for the same 10 ppm HCl standard was reduced to about 25 minutes for unconditioned glassware, and 20 minutes for conditioned glassware.

A stable HCl response time for both the ultra high purity quartz and Teflon coated filters was achieved in virtually the same amount of time (about 20 minutes), indicating that these filters have little affect on HCl adsorption.

The following Table summarizes the results

Table 2.

<u>Front-Half Glassware</u>	<u>Measurement Temperature</u>	<u>Response Time</u>
Unconditioned	250° F	50 minutes
Conditioned	250° F	40 minutes
Unconditioned	350° F	25 minutes
Conditioned	350° F	20 minutes

Part I Discussions

- Using a 350°F measurement system temperature reduced the measurement system response time by a factor of 2. This suggests that many of the past noted discrepancies between Method 26 and the infrared methods were based on the large temperature difference between the methods. (350°F for the IR methods versus 250°F for Method 26)
- The measurement system response time for conditioned glassware was slightly less than that for fresh glassware. It is expected that the time to condition the glassware is a function of the relative surface area of the glass. These experiments used a 3' glass lined probe and 3" diameter filter holders and filters. This suggests that some of the past noted discrepancies between Method 26 and the infrared method results were due to lack of glassware equilibration between the effluent and the front half of the M26 trains.
- Together, the combined effect of temperature discrepancies between the methods and the conduct of the methods (lack of sampling system equilibration in M26) can account for the negative biases observed in past comparative efforts.
- The ultra high purity quartz and Teflon coated filtration media gave similar responses to the HCl in simulated effluent.

PART II – HCl Evolution and Adsorption Studies

The purpose of these studies was to understand more fully the effects of CKD and LKD on quantifying HCl. Two sets of experiments were conducted to determine; 1) whether positive biases can arise from HCl evolving from CKD and LKD under sampling system conditions, and 2) the adsorptive capacity of the CDK and LKD for gaseous HCl. Different types of CKD and LKD samples were investigated.

Figure 2 presents a schematic of the Part II experimental apparatus, and Table 3. presents the chemical analysis results of the various dust samples used in these experiments.

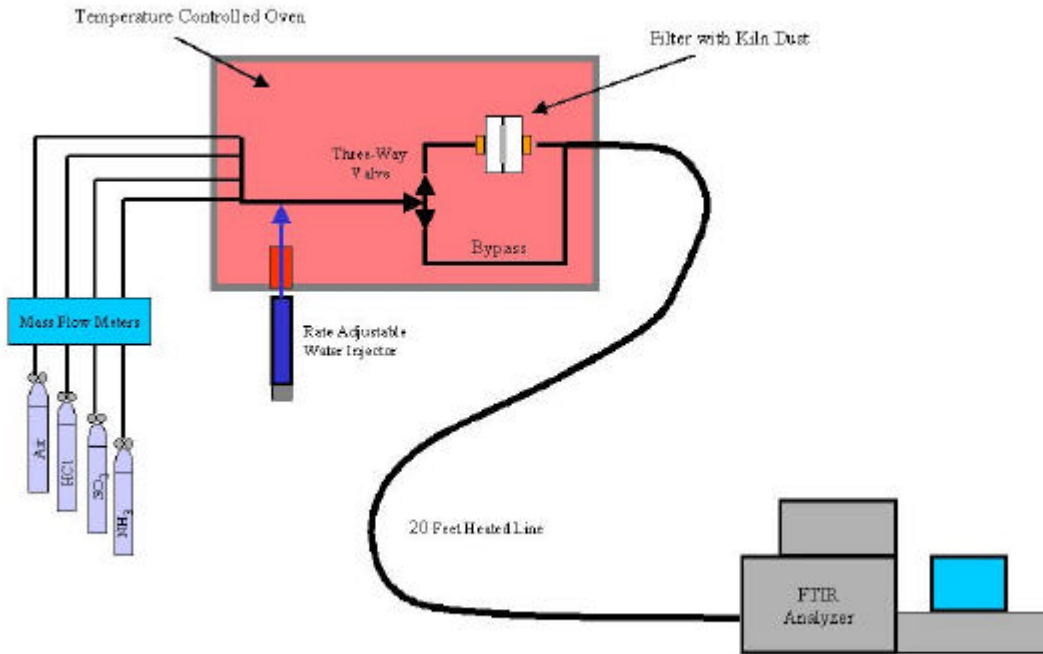

Figure 2. FTIR Dust Adsorption Studies Apparatus

Table 3. CKD/LKD Analysis (all Numbers Expressed in Percentage)

Compounds	CKD#1	CKD#2	CKD#3*	LKD#1**	LKD#2**
<i>Process Type</i>	<i>Long Wet Kiln</i>	<i>Long Wet Alkali By-pass</i>	<i>Long Dry</i>	<i>Straight Rotary</i>	<i>Straight Rotary</i>
Free Lime	5.6	25.1	12.7	Not Done	Not Done
Cl-	0.8	0.11	0.07	Not Done	Not Done
SiO ₂	14.6	19.4	10.5	2.04	3.62
Al ₂ O ₃	2.99	4.35	2.84	0.23	1.08
Fe ₂ O ₃	1.88	51.7	1.99	0.84	1.15
CaO	42.6	60.5	54.25	44.75	47.83
MgO	2.23	1.02	3.31	31.18	14.19
SO ₃	9.22	1.27	2.11	6.31	5.58
Na ₂ O	0.63	0.23	0.37	0.2	0.1
K ₂ O	5.0	2.08	1.12	0.26	0.48
TiO ₂	0.21	0.27	0.16	0.04	0.08
P ₂ O ₅	0.05	0.2	0.04	0.01	0.02
Mn ₂ O ₃	0.03	0.03	0.03	0.02	0.01
SrO	0.05	0.08	0.05	0.02	0.03
% Calcination	56.4	84.9	48.7	70.7	41.1
LOI	19.4	7.7	22.1	13.9	24.5

* *Used only during the M26/FTIR comparison studies (Part III)*

** *A 50:50 blend of these dusts were used in all experiments (kilns had common baghouse)*

A. HCl Evolution Studies

Samples of cement kiln dusts 1 & 2 and the lime kiln dust were used. These dusts represented varying degrees of calcination, percent free lime and chloride content. The dust samples were loaded onto quartz filters. Simulated effluent was directed through each of the 1.0-g samples at 350°F. No tests were conducted at the 250°F temperature since it was proven that this temperature could be the cause of negative bias. An FTIR was used to determine whether HCl could be evolved from the dust at measurement system temperatures.

B. HCl Adsorption Studies on CKD and LKD with Simulated Effluent

Samples of the same two cement kiln dusts and one lime kiln dust were loaded onto individual quartz filters and simulated effluent was directed through each of the 0.05-g samples to determine the effect of kiln dust on quantifying HCl. The concentration of water vapor, oxygen and HCl was held constant while the concentration of SO₂ was varied as each experiment progressed. During the LKD experiment ammonia was added also to determine the effect of quantifying HCl.

Part II - Results

A. HCl Evolution Studies - Gaseous HCl was not evolved from the CKD or LKD samples under the experimental conditions used during this study. This was true even with CKD #1 which had a chloride content of approximately 0.8%. In the latter case, a 2 lpm and a 1.0-g. of CKD sample could theoretically release 44 PPM of HCl.

B. HCl Dust Adsorption Studies – All CKD and LKD samples demonstrated some adsorptive capacity for HCl. The presence and amount of SO₂ in the simulated effluent greatly affects the amount of HCl that is adsorbed by the dust. An example of these phenomena is depicted in Figure 3. This figure shows that the HCl concentration drops as the simulated effluent is directed through the dust sample, and HCl adsorption on the dust decreases with increasing SO₂ concentrations in the simulated effluent.

As expected, the addition of ammonia (NH₃) to the simulated effluent resulted in an immediate decrease in the observed concentration of HCl as measured by the FTIR.

Part II – Discussions

- HCl is not evolved at 350°F from CKD or LKD in the presence of simulated effluent. This eliminates one source of suspected positive bias.
- All of the dust samples adsorbed HCl. This suggests that an effective HCl measurement system should minimize the collection of particulate matter during sampling.

- The adsorption of HCl by the CKD and LKD samples is affected by the relative concentration of SO₂ in the effluent. The dust samples preferentially adsorb SO₂ over HCl. This suggests that effluent having a higher relative SO₂ concentration at the inlet to a baghouse will allow more HCl to pass through the filter cake collected on the bags. (An ESP likely will not exhibit as great of an effect due to the lack of filter cake through which the effluent passes.)
- The reaction of gaseous HCl with ammonia (NH₃) to form solid ammonium chloride (NH₄Cl) is well known. At stack temperatures common to baghouse and ESP controlled kilns (300°F to 450°F), an equilibration between the gaseous HCl/NH₃ and the condensed NH₄Cl certainly exists. It is impossible to know the exact partition ratio between the gas and particulate phases of these compounds. Furthermore, it is very difficult to control the effects of these partitioning reactions within various sampling system components. The only means to measure the gaseous HCl with any accuracy and precision in the presence of this mixture is to maintain the sampling system components as close to the stack temperature as possible within the practical constraints of the measurement system. Even with these precautions, the presence of NH₄Cl in kiln effluent will probably result in some high bias in ion chromatographic analysis of impinger solutions.

HCl Conc. Changes with SO2 Addition - San Antonio By-Pass Dust

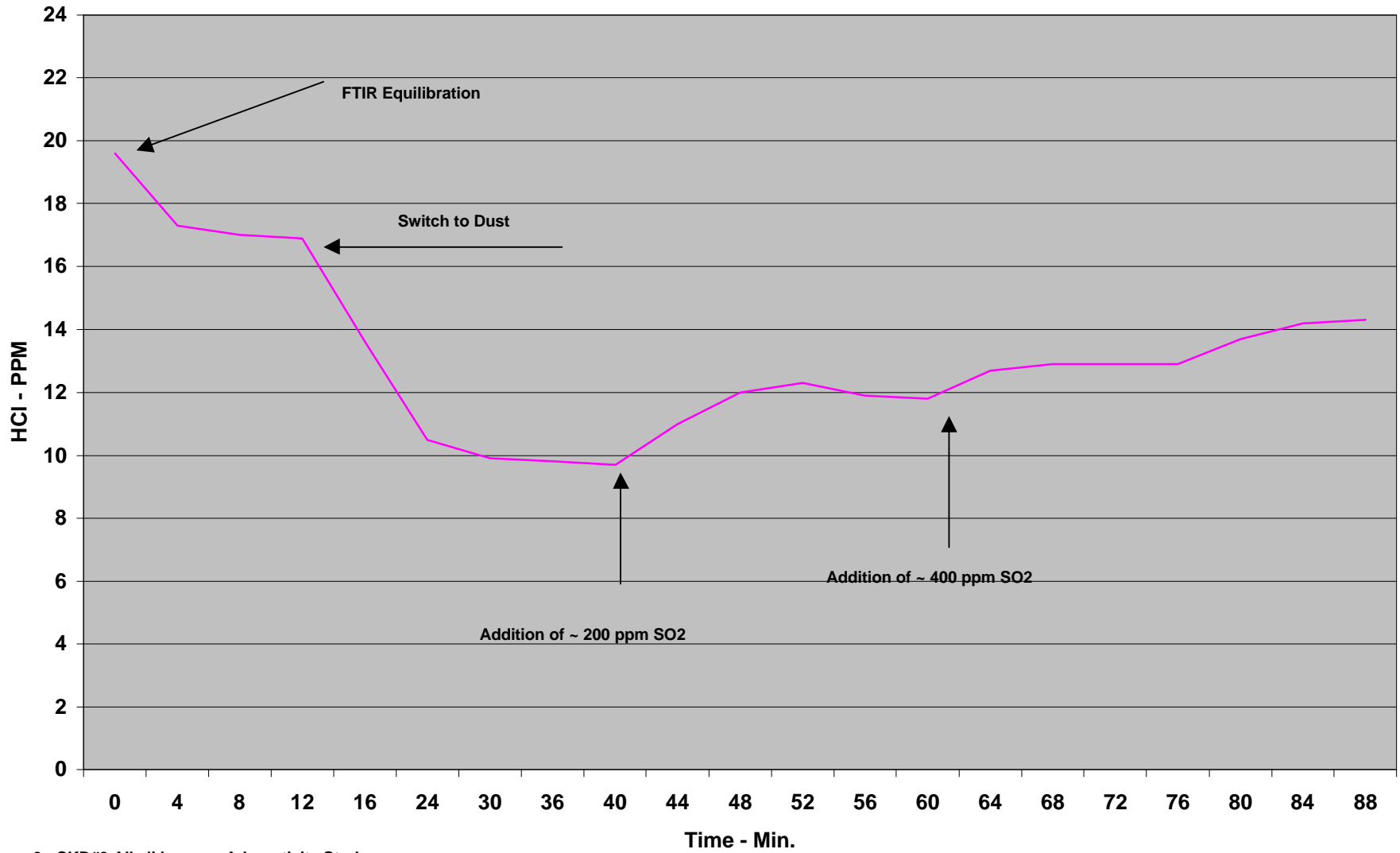

Figure 3. CKD#3 Alkali by-pass Adsorptivity Study

PART III - FTIR/Modified M26 Comparison Studies

The purpose of these studies was to determine whether the results from the previous experiments could be used to make simple modifications to EPA M26 so that the results of the ion chromatographic impinger analyses are compare to those provided by the FTIR.

Samples of all three cement kiln dusts and one lime kiln dust (50:50 mixture of the two samples provided) were loaded onto separate quartz filters. Two sets of filters containing 0.05g samples were assembled for each experiment; one for the FTIR and one for the improved impinger method. The impinger method was modified from that prescribed by M26 by using conditioned glassware (glassware previously passivated by HCl and simulated effluent), and by operating the front half of the train at 350°F temperatures rather than 250°F. Figure 4 presents a schematic of the experimental apparatus used in these studies.

Simulated effluent was directed simultaneously through the FTIR and the impinger train to compare the HCl concentration results. These experiments were conducted at two water vapor concentrations and at three HCl concentrations. The improved impinger method and the FTIR run were exactly 60 minutes in duration. The impinger train collected approximately 120 liters of gas sample (2 lpm for 60 minutes.)

A blank run using no dust was conducted to compare directly the FTIR and impinger results in the absence of dust. The HCl certified gas standard also was analyzed directly by both methods.

Figures 5 and 6 presents graphical representations of the FTIR response with time during two of these experiments. These graphs are annotated to contain information regarding the percent water vapor concentration, the expected results, and the results from the M26 ion chromatographic analysis of the impinger solutions.

Figure 6 presents a bargraph (corresponding to Figures 5 and 6) that directly compares the FTIR and impinger results to each other and to the expected value(s). The CKD#1 results are presented in these figures for continuity.

The expected values depicted in the bargraphs were calculated three separate ways; 1) the expected value based on the manufacturer' certified analysis and application of dilution factors, 2) the expected value based on direct cylinder analysis by the FTIR and application of dilution factors, and 3) the expected value based on direct analysis of the cylinder by the impinger train and application of dilution factors.

For each case, the error of the measurement is a combined effect of the calibration gas uncertainty ($\pm 5\%$ or 5 ppm), the error of the calibrated dilution system, and the error of the analytical methodology used (in this case the FTIR quantification algorithm and the ion chromatographic analysis of the impinger solutions).

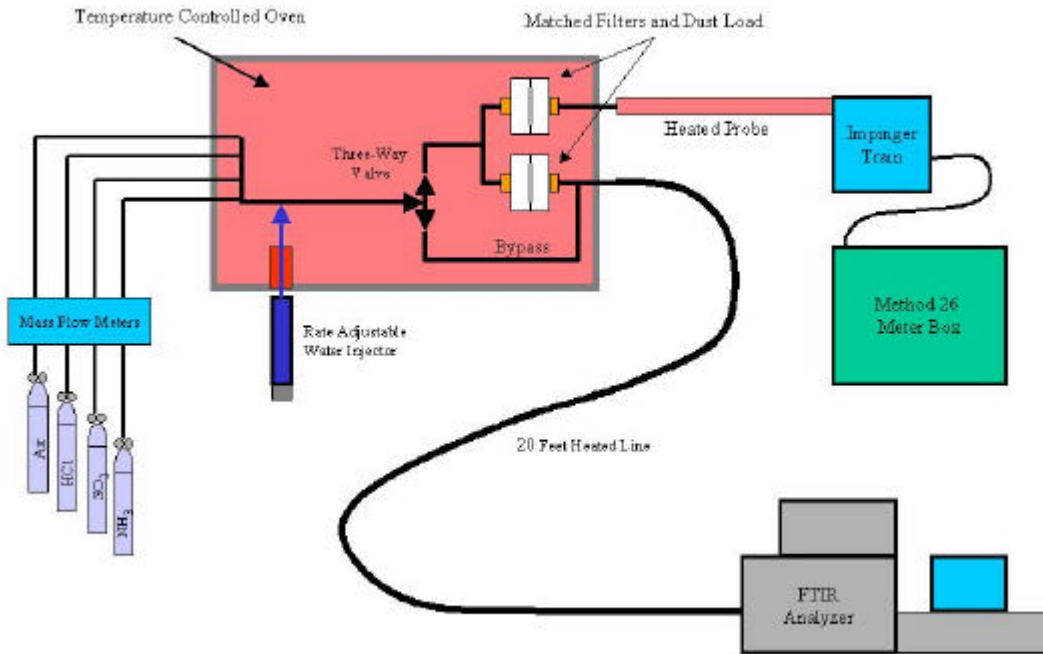

Figure 4. FTIR and Method 26 Comparative Studies Apparatus

Part III - Results

Overall, the FTIR measurement results were generally higher than expected and the improved impinger method results were generally lower than expected at concentration levels from 5-20 PPM.

At the 5 PPM HCl concentration level, the FTIR results were approximately 2 PPM (40%) higher, and the impinger results were approximately 1 PPM (20%) lower than the expected value based on the certified tag value.

At the 10-PPM HCl concentration level, the FTIR results were approximately 3-6 PPM (30-60%) higher than the value expected based on the certified tag value. The modified impinger results were approximately 0.8 to 3 PPM (8-30%) lower than the value expected based on the certified cylinder tag value.

At the 25 PPM HCl concentration level, the FTIR results were approximately 11 PPM (45%) higher, and the impinger results were approximately 1 PPM (3%) lower than the expected value based on the certified tag value.

From time to time the water injection system had to be refilled during the course of these experiments. This led to the discovery of an unexpected phenomenon. The HCl concentration varied proportionately with effluent water vapor content.

FTIR Continuous Data During M26 Comparison Run - CKD#1

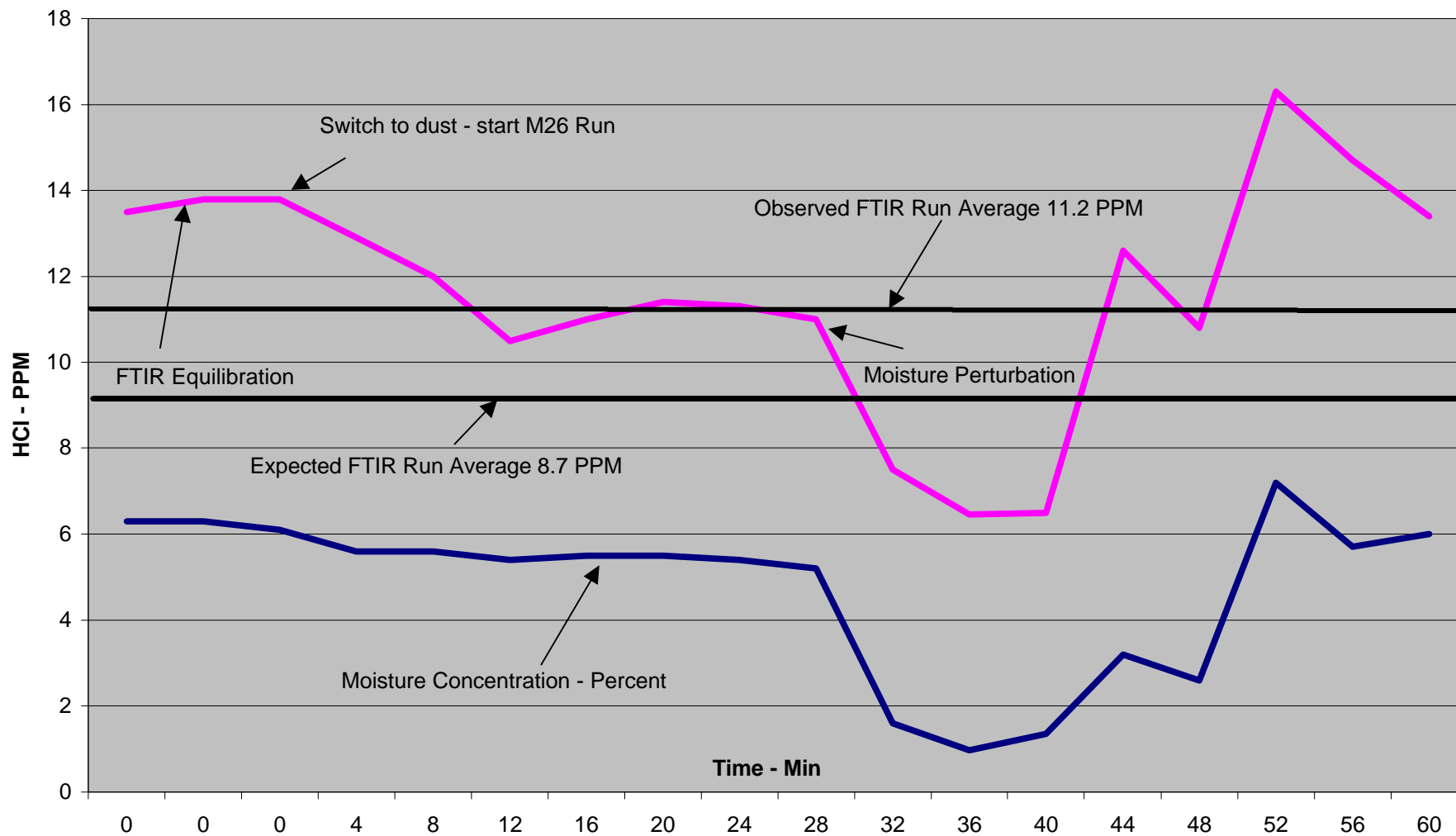

Figure 5. FTIR Trend with Time During Comparison Study - CKD#1

FTIR Continuous Data During M26 Run Comparison - CKD#1

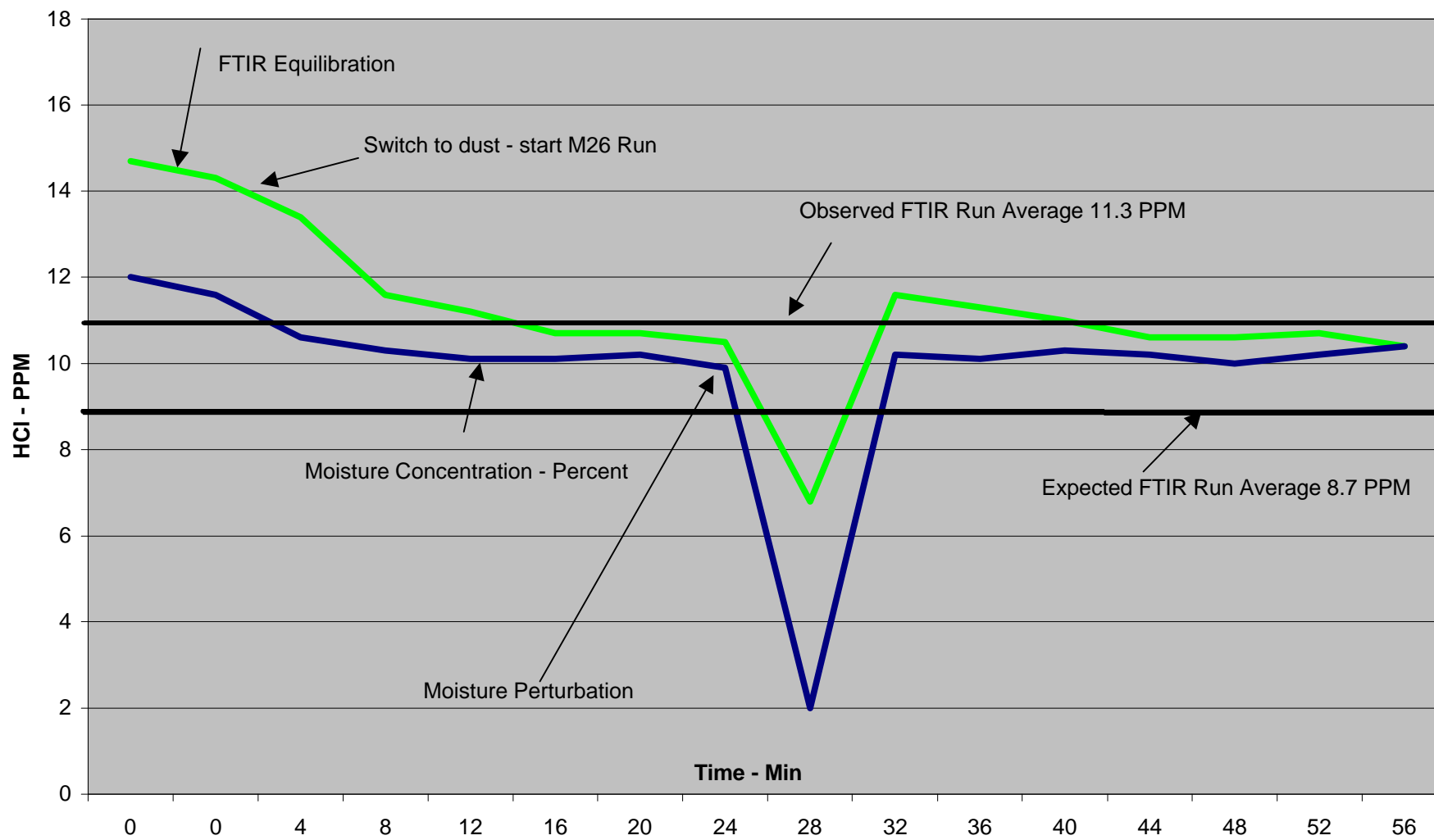

Figure 6. FTIR Trend with Time During Comparison Study - CKD#1

M 26/FTIR Comparison results - CKD#1

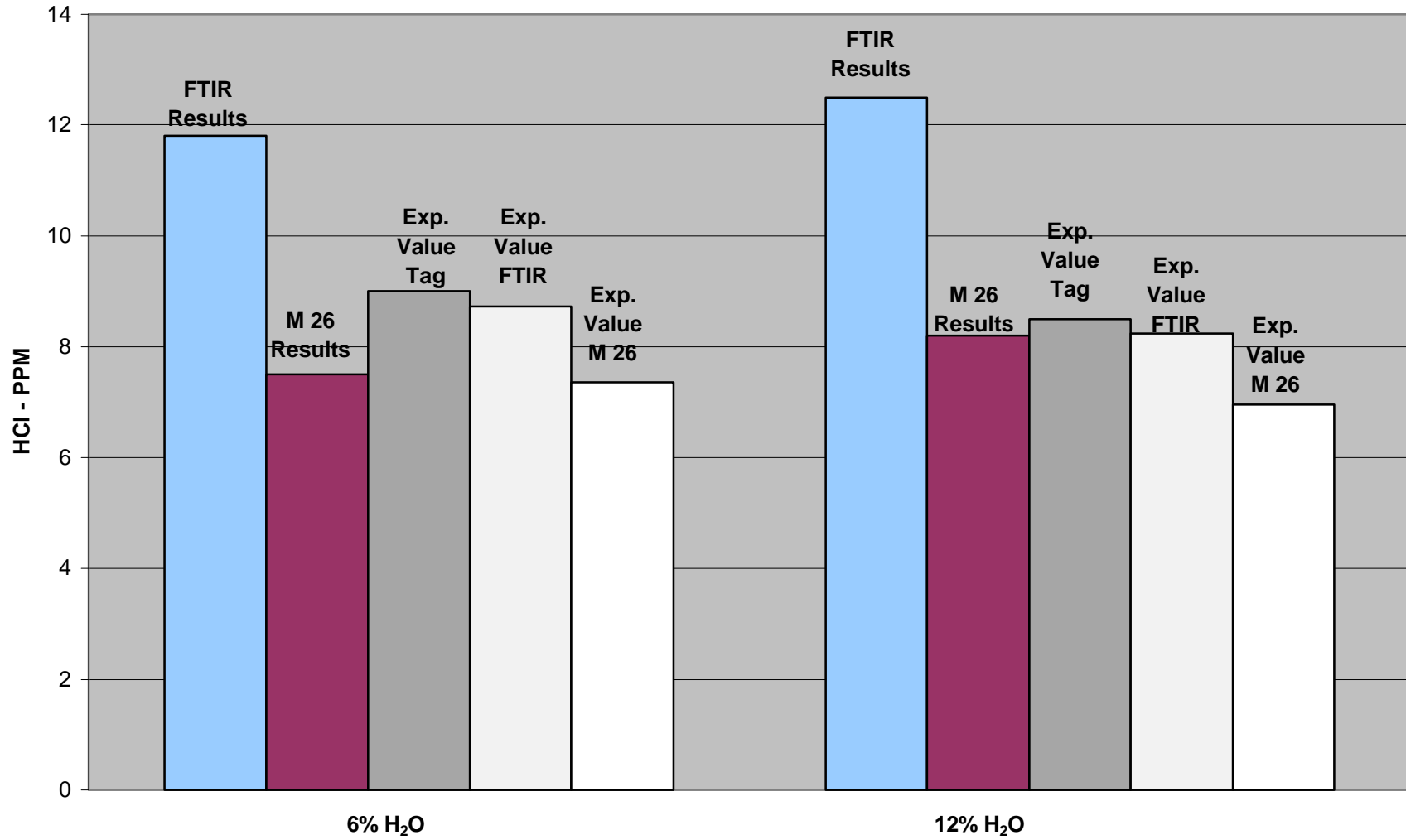

Figure 7. FTIR/Modified M26 Comparison Results

Part III – Discussions

Operating the FTIR and the improved impinger measurement system at the same temperature with the same filtration media produces results that are similar. This is perhaps the most important aspect in obtaining comparable results for highly reactive gases in difficult to measure effluent.

The experiments conducted during this study were operated at the 350°F. It is recommended that this temperature is used after baghouse and ESP controlled kilns where effluent temperatures typically exceed 350°F. For cooler stacks, the measurement system temperature should be at least 20°C higher than the effluent temperature to prevent condensation of the gas stream, but not so high as to vaporize material condensed on the particulate matter.

In most cases, the FTIR results were higher and the improved impinger based results were lower than the value expected from the certified tag value. The FTIR results are likely high due to a non-linearity effect, which can be corrected using software. (It is particularly important to include low level HCl calibration standards in the FTIR reference library when attempting to analyze accurately these low concentration levels.) The improved impinger results are within 20% of the value (1ppm) at the 5-PPM concentration level. This is likely the expected accuracy of the method.

The direct correlation of HCl with percent water vapor is likely explained by an adsorption effect. When water vapor is present, it occupies sites in the measurement system at the molecular level. Perhaps by hydrogen bonding with the fluorinated groups in the Teflon sampling components. Removing water vapor frees the active sites so that HCl can be adsorbed. The rapid displacement of HCl by water vapor as the moisture level is again increased suggests that the water is preferentially adsorbed in the system over HCl. This has a direct impact on instrumental test methods where dry calibration gases are used to test the sampling system integrity before switching to source effluent.

RECOMMENDATIONS

Numerous comparative studies between impinger-based and IR-based HCl measurement methods were conducted in the past using greatly disparate temperatures, and filtration media. The impinger testing was performed using freshly cleaned glassware, while the instrumental IR-based methods employed sample line conditioning with effluent before starting the run. Impinger-based methods are also designed to collect particulate matter effectively even when single point non-isokinetic sampling is performed, while the instrumental IR-based methods often take measures to reduce the amount of particulate collected (by turning the nozzle backwards, etc.).

An additional source of error between the methods is the primary calibration standards used, and the degree of infrared analyzer linearity in the measurement range.

Together the combination of sampling system temperature differences, the degree of sample component conditioning, the amount of particulate matter collected, and the

differences between the reference standards (calibration gases versus liquid ion chromatographic standards) can more than account for differences encountered in past comparative measurement results.

Simple modifications to Method 26 such as raising the temperature, conditioning the front half of the sampling train components, and reducing the amount of particulate matter collected can be made to minimize the differences between the methods.

Perhaps the most important issue that became evident during the course of these experiments is that measuring HCl accurately at the 3-10 PPM level of concern is very challenging. Given a 20-30% level of accuracy for both methods (under the best circumstances) means that a relative error of from 0.5 to 3 PPM can be realized at any time. This makes it difficult if not impossible for a large facility having 3 or more kilns to determine major source status under the Clean Air Act Amendments.

Further work in this area should focus on how to measure HCl more accurately at low concentrations. Design of a sampling probe configuration that rejects particulate matter is recommended, along with field testing of the modified method. Testing should be conducted using a paired train configuration so that the precision of the method can be determined. Additionally, a means of determining the accuracy of the method should be investigated. This would entail procedures such as challenging the impinger method with a known quantity of HCl (from a certified gas standard) through the entire sampling train, including the probe and filter assembly, at the end of a test series.

ACKNOWLEDGMENTS

The authors would like to acknowledge the Portland Cement Association and its member companies particularly Blue Circle Cement, Capitol Aggregates, and California Portland. Acknowledgments also go to the National Lime Association, Clean Air Engineering, and Construction Test Laboratories.

REFERENCES

1. Code of Federal Regulations 40 CFR Part 63, Appendix A, U.S. GPO, Washington, DC 20402
2. Code of Federal Regulations 40 CFR Part 60, Appendix A, U.S. GPO, Washington, DC 20402
3. National Emissions Standards for Hazardous Air Pollutants; Portland Cement Manufacturing Industry; March 24, 1998 (63 FR 14182).
4. National Emissions Standards for Hazardous Air Pollutants; Portland Cement Manufacturing Industry; June 14, 1999 (64 FR 31897).

KEY WORDS

FTIR, Method 26, ASTM, HCl, Emissions Measurement, Portland Cement, MACT Standards.